

A Review on Recent Developments in Wireless Power Transfer

Teja Sreenu Tadivaka,

Department of Electrical and Electronics Engineering, Koneru Lakshmaiah Education
Foundation, Vaddeswaram, AP, India

T Vijay Muni,

Department of Electrical and Electronics Engineering, Koneru Lakshmaiah Education
Foundation, Vaddeswaram, AP, India

R B R Prakash,

Department of Electrical and Electronics Engineering, Koneru Lakshmaiah Education
Foundation, Vaddeswaram, AP, India

P Srinivasa varma

Department of Electrical and Electronics Engineering, Koneru Lakshmaiah Education
Foundation, Vaddeswaram, AP, India

Abstract:

This paper reviews various wireless charging techniques and most recent developments in wireless power transfer. As technology is building up, the usual charging with wires is replaced by wireless charging (WC), so that charging and controlling turns out to be simple and reduction of wires increases the Power Transmission Efficiency (PTE). In this paper various wireless charging methods are reviewed and limitations of each technique are identified (i.e. inductive power transfer and capacitive power transfer). The scope for development in terms of designing of converters and impedance matching networks used in transmitter and receiver sides is highlighted.

Key words: wireless charging, power transmission efficiency.

1. Introduction:

Every year thousands of new inventions that shape and make our lives more comfortable than it was the previous year. As the number and complexity of these devices grows, we are facing the problem of charging these devices. Even though battery and power supply technologies

(switched power electronics, High Voltage DC, etc.) have become more efficient over the years, it is definitely more desirable to have a powering/recharging solution as ubiquitous and convenient as wireless internet.

1.1 Wireless power transmission (WPT)?

It is the transfer of energy from one circuit then onto the other without utilizing wires. Conventional energy transfer is with the help of wires. On the other hand, the wireless transmission is made conceivable by utilizing different advancements. In general, most of the electrical energy exchange is through wires and during transmission most of the energy loss is occurring. The general block diagram of WPT is shown in fig.1. This contains ac-dc conversion, impedance matching networks, transmitter and receiver circuits and load.

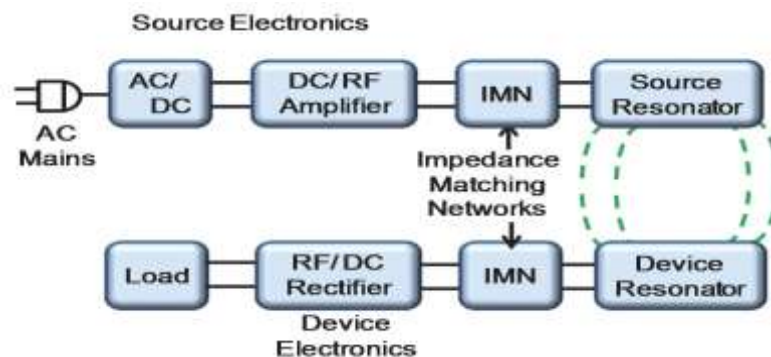

Figure.1: Block diagram of a wireless energy transfer system

1.2 Different Types and Technologies of WPT.

Wireless power transmission methods are divided into 2 categories according to the distance of the transmitted power.

- **Near-field techniques**

1. Capacitive Coupling
2. Inductive Coupling
3. Air Ionization

- **Far-field techniques**

1. Microwave Power Transmission (MPT)
2. LASER power transmission

Nicolas tesla's (10 july1856-7 January 1943) experiment [1] was basis for all development taking place present. Most of the public thinking that by using wireless power transfer it causes damage to environment and then human health, but as per the IEEE standard, the radiation levels are limited to certain levels by the safety studies [1]. Then the public contact of WPT fields would be beneath present safety guidelines (ANSI/IEEE exposure standards) [18]. Different Types and Technologies of WPT in use are shown in fig.2

1.3 Far-field techniques:

Far-field techniques use propagating electromagnetic waves that transfer energy the similar to radios transmit signals. This technique has been effectively used to power UHF RFID labels, at an operating range of 10 meters [2], [3].

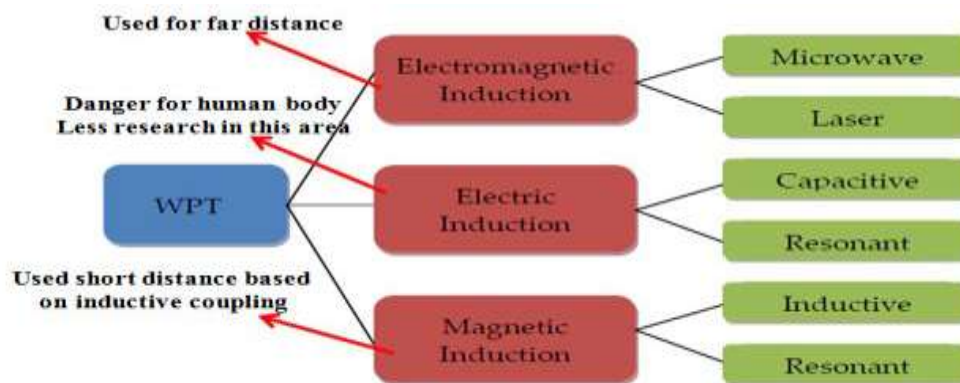

Figure. 2 Different Types of WPT

Limitations:

- The inherent tradeoff amongst directionality
- Transmission efficiency is very less.

1.3 Capacitive coupling:

Capacitive coupling uses electro static induction to transmit power between electrodes like metal plates. Capacitive coupling has only been used practically in a few low power applications like charging battery powered portable devices, USB devices, lamps and small robots etc.

Limitations of Capacitive coupling:

- Very high voltages on the electrodes can be hazardous.
- Can cause unpleasant side effects such as noxious ozone production.
- Electric fields interact strongly with most materials, including the human body.

An example of works done so far

In [4] proposed a concept of designing capacitive power transfer. He uses a class E resonant inverter due to its efficient conversion from DC-AC and its lower switching losses than other inverters. They validate the CPT using class E inverter on a hardware device with 1 MHz frequency and a coupling gap of 0.25mm. He also proposes a frequency tracker to tune the operating frequency with respect to change in coupling gap and achieved an efficiency of 96.3% for 0.25mm and 91% for 2mm. he also mentioned the limitations of IPT with respect to CPT [5]-[7]. Proposed CPT System with FTU Block Diagram is shown in fig.3.

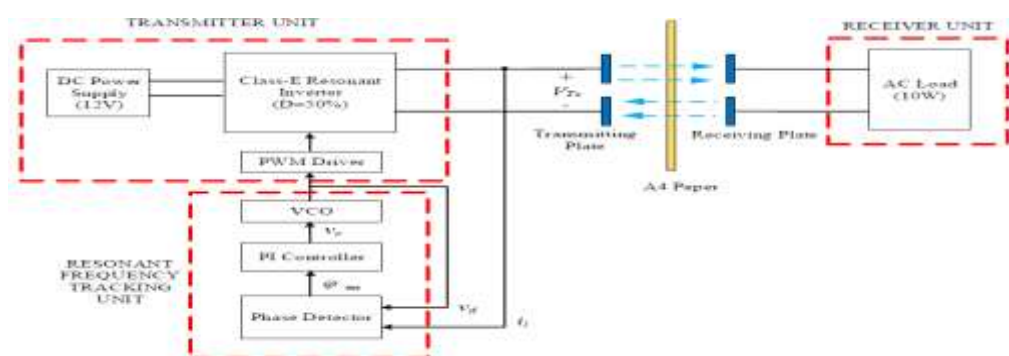

Figure.3. Proposed CPT System with FTU Block Diagram.

In [8], authors have proposed wireless power distribution with capacitive coupling to overcome disadvantages in magnetic coupling like power decrease for inexact connection. In this paper a new WPT using capacitive coupling is proposed excited by multi-stage switched mode active capacitor to increase provided power. The proposed framework enhances power transfer efficiency without LC resonance so that it is robust against parameter change. In addition the proposed active negative capacitor works stable without any feedback loop.

1.4 Inductive coupling:

In inductive coupling power is transferred between the coils by a magnetic field. Inductive coupling (or near-field) techniques do not depend on propagating electromagnetic waves. Applications include rechargeable toothbrushes and the recently proliferating “power” surfaces [9]. Recently electric vehicles are using wireless power to charge the battery on the go [10]. Magnetically coupled resonators are used for wireless power transfer [11] have shown the potential to deliver power with more efficiency, and at longer ranges the traditional inductively coupled schemes. For achieving a good efficiency an adaptive

Research paper

© 2012 IJFANS. All Rights Reserved, UGC CARE Listed (Group -I) Journal Volume 8, Issue 1, 2019

frequency tuning technique is also introduced in the recent wireless power transfer for nearly any distance.

An example of works done so far

In [11], authors have proposed a concept of charging electrical vehicles (EV) by using wireless concept. They mentioned that by charging EV using wireless charging i.e inductive power transfer, an efficiency of 90% above can be achieved by increasing distance of several hundred millimeters at kilowatt power level. The advances make the WPT very attractive to the electric vehicle (EV) charging applications in both stationary and dynamic charging scenarios. Fig.4 depicts the concept of charging electrical vehicles.

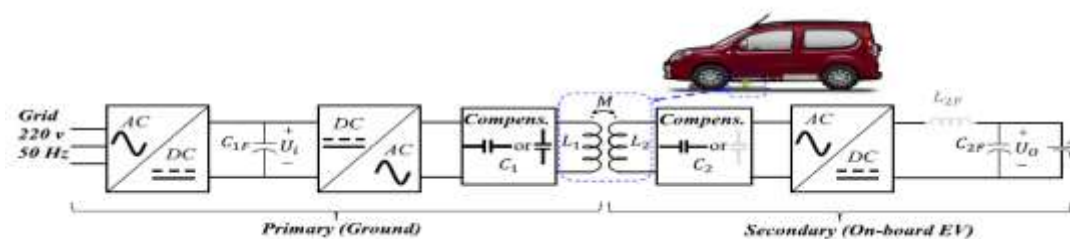

Figure.4. General Block diagram for a contactless charger for EV.

In rail transit vehicles the motor drives are powered by inductively coupled power transfer systems [12] are recent advancements. It uses closed loop control by phase shift control [13, 14] method to output voltage of ICPT. They validate the above system by using simulation software.

The combine topology of inductive wireless power transfer (IPT) and capacitive wireless power transfer (WPT) is proposed in [15] which to reduce the external component number and simplify the circuit design. This configuration utilizes both electric fields and magnetic fields in the resonant circuits. On both sides of this topology LC compensation (LCLC, LCC) is used [16]. It is validate by using a 3.0 kW experiment [17] prototype as shown in fig.5 when both couplers are well aligned he achieved an efficiency of 94.5% and an output of 2.84kw. But the output drops to 1.35kw and efficiency drops to 91.49% when both couplers have a displacement of 20cm [18]. Table.1 shows comparison of each method in technical aspect.

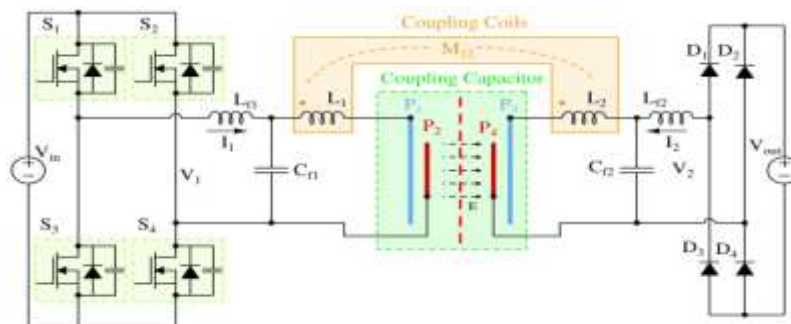

Figure.5. Circuit Topology of the LC compensated IPT-CPT System.

Table.1 – Comparison of the presented methods

Method's name	Power range	Distance range	commercial	efficiency
Magnetic resonance	Up to 60 W has been reported [19]	Up to 8 times of the transmitter and the receiver [19]	Not expensive [20]	Up to 45% have been reported [19]
Capacitive coupling	Up to 60 W has been reported [19]	Up to 8 times of the transmitter and the receiver [19]	Not expensive [20]	Up to 45% have been reported [19]
Microwave	Up to 100KW feasibility study [9]	transmitting from the Moon to the Earth [10]	Expensive	Up to 54% has been reported [12]
Laser	Up to several hundred KW has been reported [22]	Up to 1 km has been reported [22]	Expensive	Up to 30% has been reported [21]

2. Future scope:

From the review of various methods it is clear that presently we are in the process of switching over (partly or fully) from Wire Power Transmission to Wireless Power Transmission. By developing new converter designs and impedance matching circuits, we can achieve more efficient, long distance transfer and cost effective model. Our future will be wireless.

3. Conclusion:

In this paper the concept of wireless power transmission was being discussed. After a brief history, four methods of WPT were introduced. Then each of the methods was briefly explained. In the next section, the methods were compared to each other in several aspects. It is shown that the far field methods are more expensive than the near field methods. Then challenges and the future views for wireless power transmitting were discussed. As we saw, WPT is not widely used because of some reasons such as small amount of efficiency, commercially expensive etc. And in the last section, examples of works done so far for each method were presented along with future scope.

REFERENCES

- [1]. Tesla N. Apparatus for transmission of electrical energy. Google Patents, 1900.
- [2] S. Ahson and M. Ilyas, RFID handbook : applications, technology, security, and privacy. Boca Raton: CRC Press, 2008.
- [3] A. Sample, D. Yeager, P. Powledge, A. Mamishev, and J. Smith, "Design of an rfid-based battery-free programmable sensing platform," *Instrumentation and Measurement, IEEE Transactions on*, vol. 57, no. 11, pp. 2608–2615, Nov. 2008.
- [4] Yusmarnita Yusop, Shakir Saat, Sing Kiong Nguang, Huzaimah Husin, and Zamre Ghani "Design of Capacitive Power Transfer Using a Class-E Resonant Inverter" *Journal of Power Electronics*, Vol. 16, No. 5, pp. 1678-1688, September 2016
- [5] J. Huh, W. Lee, S. Choi, G. Cho, and C. Rim, "Frequency domain circuit model and analysis of coupled magnetic resonance systems," *Journal of Power Electronics*, Vol. 13, No. 2, pp. 275-286, Mar. 2013.
- [6] X. Wei, Z. Wang, and H. Dai, "A critical review of wireless power transfer via strongly coupled magnetic resonances," *Energies*, Vol. 7, No. 7, pp. 4316-4341, Jul. 2014.
- [7]. http://www.nasa.gov/home/hqnews/2009/nov/HQ_09-261_power_beam.html
- [8]. Fnato, Hirohito Dept. Electr. & Electron. Eng., Utsunomiya Univ., Utsunomiya, Japan Chiku, Yuki; Harakawa, Kenichi, "Wireless power distribution with capacitive coupling excited by switched mode active negative capacitor", *Electrical Machines and Systems (ICEMS)*, 2010 International Conference
- [9] PowerMat Inc., <http://www.powermat.com>, Nov. 2009.

Research paper

© 2012 IJFANS. All Rights Reserved, UGC CARE Listed (Group -I) Journal Volume 8, Issue 1, 2019

- [10] S. Li and C.C. Mi, "Wireless power transfer for electric vehicle applications," *IEEE J. Emerging Select. Topics Power Electron.*, vol. 3, no. 1, pp. 4–17, Mar. 2015.
- [11] Cai Hua, Shi Liming, Li Yaohua. et al., "Output Power Adjustment in Inductively Coupled Power Transfer System," *Transactions of China Electrotechnical Society*, Vol. 29, No. 1, 2014.
- [12] Pengfei Wu, Liming Shi, Hua Cai, and Yaohua Li "A Power Control Based on Inductively Coupled Power Transfer System for Motor Drives of Rail Transit Vehicles" *Journal of International Conference on Electrical Machines and Systems Vol. 4, No. 4, pp. 73~77, 2015*
- [13] Su Yugang, Wang Zhihui, Sun Yue, et al., "Modeling of contactless power transfer systems with a phase-shifted control method," *Transactions of China Electrotechnical Society*, Vol. 23, No. 7, pp. 92-97, 2008.
- [14] Cai Hua, Shi Liming, Li Yaohua. et al., "Output Power Adjustment in Inductively Coupled Power Transfer System," *Transactions of China Electrotechnical Society*, Vol. 29, No. 1, 2014.
- [15] Fei Lu, Hua Zhang, Heath Hofmann, Chris Mi, "An Inductive and Capacitive Combined Wireless Power Transfer System with LC-Compensated Topology" *IEEE Transactions on Power Electronics* 2015.
- [16] F. Lu, H. Zhang, H. Hofmann, and C. Mi, "A Double-sided LCLC-Compensated Capacitive Power Transfer System for Electric Vehicle Charging," *IEEE Trans. Power Electron.*, vol. 30, no. 11, pp. 6011-4014, 2015.
- [17] J. Kim, B. Lee, J. Lee, and S. Lee, "Development of 1MW Inductive Power Transfer System for a High Speed Train," *IEEE Trans. Ind. Electron.*, vol. 62, no. 10, pp. 6242-6250, 2015.
- [18] J. Dai and D. Ludois, "A Survey of Wireless Power Transfer and a Critical Comparison of Inductive and Capacitive Coupling for Small Gap Applications", *IEEE Trans. Power Electron.*, vol. 30, no. 11, pp. 6017-6029, 2015.
- [19]. Andre kurs, Aristeidis karalis, Robert Moffatt, J.D. Joannopoulos, Peter Fisher, Marin Soljagic, "Wireless Power Transfer via Strongly Coupled Magnetic Resonances", *International Journal of Advanced Engineering & Applications*, Jan. 2010, pp. 177-181

Research paper

© 2012 IJFANS. All Rights Reserved, UGC CARE Listed (Group -I) Journal Volume 8, Issue 1, 2019

[20]. Derek Runge, Carl Westerby, “Design Review: Wireless Power Transmission Using Resonant Coils”, ECE 445, Fall 2008

[21]. www.powerbeaminc.com

[22]. Shreyas Srinath, Sahana S Bhandari, “Optic based wireless power transmission for wireless sensor networks”, International Journal of Engineering Research & Technology (IJERT), ISSN: 2278-0181, Vol. 1 Issue 10, December- 2012