

IOT BASED VEHICLE COLLISION AVOIDANCE SYSTEM

¹Siva Kumar J,²Srinivasulu R,³Kavitha C,⁴Anitha R

^{1,2}Associate Professor,^{3,4}Assistant Professor

Department of ECE

Tadipatri Engineering College, Tadipatri, AP

ABSTRACT:

Nowadays, the number of accidents is so high and uncertain. Accidents causes worst damage, serious injury and even death. These accidents are mostly caused by delay of the driver to hit the brake. Preventive measure such as improving visibility, auto headlights, windshield wipers, tire traction, etc. were deployed to reduce the probability of getting into an accident. Now we are at the stage of actively avoiding accidents as well as providing maximum protection to the vehicle occupants and even pedestrians. Hence in this paper, we make an attempt to propose a new automated vehicle collision avoidance system. This project is designed to develop a new system that can solve this problem where drivers may not brake manually but the vehicles can stop automatically due to obstacles by using sensors. Thus, this paper focuses on the development of a sensor based embedded system that can assist the drivers to avoid any sort of collision on the road in order to save the precious lives and also to prevent the financial loss

I. INTRODUCTION

Collisions are one of the negative effects of any transportation system and road accidents adversely impact developing countries on a regular schedule. The main reasons are inadequate infrastructure, traffic control, and accident management. South Asia, particularly India and Bangladesh are identified as the developing countries with the highest frequency of accidents. However, technological superiority is in sight that exists in a universe whereby advanced technologies are also being developed and these approaches can be used in our society to fix shortcomings. At present the Internet of Things (IoT) is a figurative concept which depicts global internet connectivity. The core idea behind the IoT concept is to spend billions if not trillions of smart devices which can assess the obtained data and detect any kind of collisions as well as general climate of the day of occurrence. By the end of 2021 it is expected that there will be 28 billion connected devices [5] and IoT systems are a network that connects devices to collect and share data, and they are utilized in a variety of applications. An ad hoc

network for automobiles is a network of moving vehicles where each vehicle acts as a node in the creation of a mobile network.

II. LITERATURE SURVEY

In this section we concentrate on different approaches used for Vehicle collision detection and accident avoidance. Various techniques to improve the automotive systems with the consideration of various parameters mention.

Nesreen Alsbou Presented Vehicle Collision Avoidance System with the help of Wireless Sensor Networks. Author make use of the wireless sensor network (WSN) to transmit the measured data in avoidance system and the using the controller area network protocol (CAN) bus to revive the data and connect the data with the controller to controlling on the actuators.

System consist of laser transmitter and receiver. And the laser transmit a burst of electromagnetic radiation and when this radiation reflect by the barrier then this reflect light transmitted by Zig Bee communication module to the controller In this case the driver able to take decision to avoid the accident as much as possible.

III. DESIGN OF HARDWARE

This chapter briefly explains about the Hardware. It discusses the circuit diagram of each module in detail.

ARDUINO UNO

The Arduino Uno is a microcontroller board based on the ATmega328 (datasheet). It has 14 digital input/output pins (of which 6 can be used as PWM outputs), 6 analog inputs, a 16 MHz ceramic resonator, a USB connection, a power jack, an ICSP header, and a reset button. It contains everything needed to support the microcontroller; simply connect it to a computer with a USB cable or power it with a AC-to-DC adapter or battery to get started.

The Uno differs from all preceding boards in that it does not use the FTDI USB-to-serial driver chip. Instead, it features the Atmega16U2 (Atmega8U2 up to version R2) programmed as a USB-to-serial converter. Uno board has a resistor pulling the 8U2 HWB line to ground, making it easier to put into DFU mode. Arduino board has the following new features:

- 1.0 pin out: added SDA and SCL pins that are near to the AREF pin and two other new pins placed near to the RESET pin, the IOREF that allow the shields to adapt to the voltage provided from the board. In future, shields will be compatible both with the board that use the AVR, which operate with 5V and with the Arduino Due that operate with 3.3V. The second one is a not connected pin, that is reserved for future purposes.
- Stronger RESET circuit.
- Atmega 16U2 replace the 8U2.

"Uno" means one in Italian and is named to mark the upcoming release of Arduino 1.0. The Uno and version 1.0 will be the reference versions of Arduino, moving forward. The Uno is the latest in a series of USB Arduino boards, and the reference model for the Arduino platform; for a comparison with previous versions, see the index of Arduino boards.



Fig: ARDUINO UNO
ULTRASONIC SENSOR

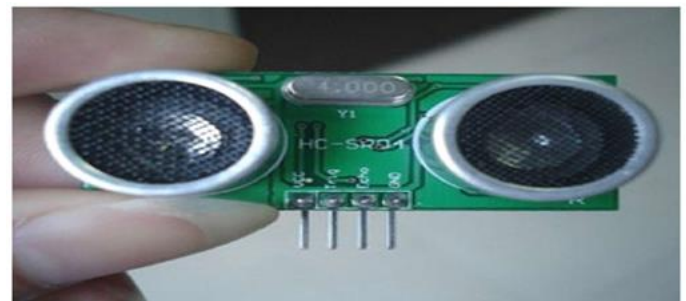

A guide to using the Arduino Ultrasonic Range Detection Sensor with Arduino in order to calculate distances from objects. In this case I'm also altering the output of an LED with PWM according to how close an object is to the sensor. So the nearer you are the brighter the LED. So if we start with the Arduino Ultrasonic Range Detection Sensor, it's an IC that works by sending an ultrasound pulse at around 40Khz. It then waits and listens for the pulse to echo back, calculating the time taken in microseconds (1 microsecond = 1.0×10^{-6} seconds). You can trigger a pulse as fast as 20 times a second and it can determine objects up to 3 meters away and

as near as 3cm. It needs a 5V power supply to run.

Adding the Arduino Ultrasonic Range Detection Sensor to the Arduino is very easy, only 4 pins to worry about. Power, Ground, Trigger and Echo. Since it needs 5V and Arduino provides 5V I'm obviously going to use this to power it. Below is a diagram of my Arduino Ultrasonic Range Detection Sensor, showing the pins. There are 2 sets of 5 pins, 1 set you can use, the other is for programming the PIC chip so don't touch them!

POWER SUPPLY:

The power supplies are designed to convert high voltage AC mains electricity to a suitable low voltage supply for electronic circuits and other devices. A power supply can be broken down into a series of blocks, each of which performs a particular function. A d.c power supply which maintains the output voltage constant irrespective of a.c mains fluctuations or load variations is known as "Regulated D.C Power Supply".

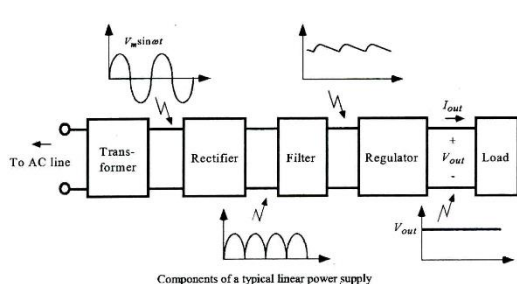

Fig: Block Diagram of Power Supply

LCD DISPLAY

A model described here is for its low price and great possibilities most frequently used in practice. It is based on the HD44780 microcontroller (Hitachi) and can display messages in two lines with 16 characters each. It displays all the alphabets, Greek letters,

punctuation marks, mathematical symbols etc. In addition, it is possible to display symbols that user makes up on its own. Automatic shifting message on display (shift left and right), appearance of the pointer, backlight etc. are considered as useful characteristics.

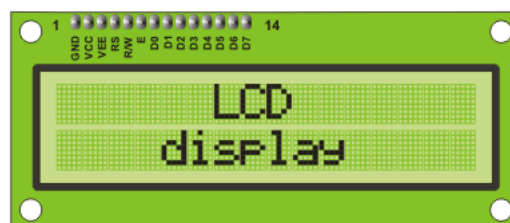
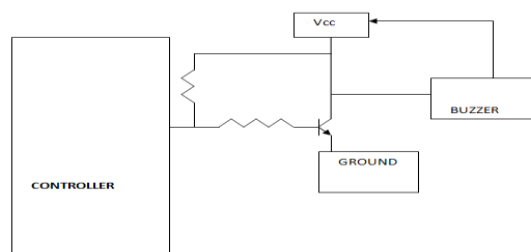

Fig: LCD

BUZZER

Digital systems and microcontroller pins lack sufficient current to drive the circuits like relays, buzzer circuits etc. While these circuits require around 10milli amps to be operated, the microcontroller's pin can provide a maximum of 1-2milli amps current. For this reason, a driver such as a power transistor is placed in between the microcontroller and the buzzer circuit.



WIFI MODULE:

The ESP8266 is a low-cost Wi-Fi microchip with full TCP/IP stack and microcontroller capability produced by Shanghai-based Chinese manufacturer, Espressif Systems.^[1]

The chip first came to the attention of western makers in August 2014 with the ESP-01 module, made by a third-party manufacturer, Ai-Thinker. This small module allows microcontrollers to connect to a Wi-Fi network and make simple TCP/IP connections

using Hayes-style commands. However, at the time there was almost no English-language documentation on the chip and the commands it accepted.^[2] The very low price and the fact that there were very few external components on the module which suggested that it could eventually be very inexpensive in volume, attracted many hackers to explore the module, chip, and the software on it, as well as to translate the Chinese documentation.^[3]

The **ESP8285** is an ESP8266 with 1 MiB of built-in flash, allowing for single-chip devices capable of connecting to Wi-Fi.^[4]

The successor to these microcontroller chips is the ESP32.



L293D:

The L293 and L293D are quadruple high-current half-H drivers. The L293 is designed to provide bidirectional drive currents of up to 1 A at voltages from 4.5 V to 36 V. The L293D is designed to provide bidirectional drive currents of up to 600-mA at voltages from 4.5 V to 36 V. Both devices are designed to drive inductive loads such as relays, solenoids, dc and bipolar stepping motors, as well as other high-current/high-voltage loads in positive-supply applications. All inputs are TTL compatible. Each output is a complete totem-pole drive circuit, with a Darlington transistor sink and a pseudo- Darlington source. Drivers are enabled in pairs, with drivers 1 and 2 enabled by 1,2EN and drivers 3 and 4 enabled by 3,4EN. When an

enable input is high, the associated drivers are enabled, and their outputs are active and in phase with their inputs. When the enable input is low, those drivers are disabled, and their outputs are off and in the high-impedance state. With the proper data inputs, each pair of drivers forms a full-H (or bridge) reversible drive suitable for solenoid or motor applications.

DC MOTOR

A DC motor is designed to run on DC electric power. Two examples of pure DC designs are Michael Faraday's homopolar motor (which is uncommon), and the ball bearing motor, which is (so far) a novelty. By far the most common DC motor types are the brushed and brushless types, which use internal and external commutation respectively to create an oscillating AC current from the DC source -- so they are not purely DC machines in a strict sense.

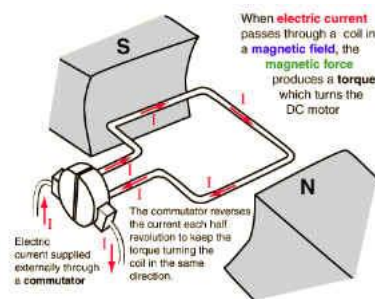

IV. BLOCK DIAGRAM:

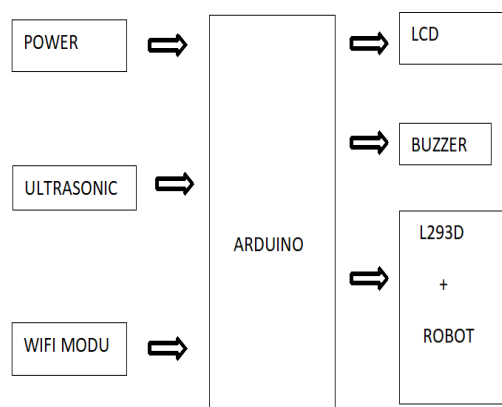

Working:

The accident avoidance system helps to avoid the regular accidents that will normally occurring on highways and in city traffic. These accidents are mainly happened by distraction, unconsciousness, and distance unknown between our vehicles. So let us consider the Indian roads and we will have 2 ultrasonic sensors where one is placed in the front and another one behind the car. Due to this sensor, we can calculate the distance of other automobiles nearing us. Thus we can locate other cars and we can protect ourselves from accidents. Arduino is a prototyping platform for controlling many devices. Through arduino, we can build many prototypes that we imagine. A basic arduino kit which forms the connection between the LCD and Ultrasonic sensor. Here the LCD is the source to display the output. Through this LCD display we can be able to see the distance of the vehicle that comes. Ultrasonic sensor is to sense the vehicle that nears about to 10 meters bread boards which allows implementing all the connection accompanied by the three LEDs. Connections are made to the arduino, LCD, LED, Ultrasonic sensor. The ultrasonic sensor is fixed in our car and it normally senses the car which is nearest to us on both front and back side. At distance of 10meter the green light will show the notification and when the car reaches 8meter he yellow color light alerts us and when the car reaches 5meter the red color light alerts us about the danger zone .The distance between one vehicle and another vehicle was displayed in LCD.

V.CONCLUSION

Collision avoidance system reduces accidents by taking certain measures to control the vehicle. In this system Internet of Things uses V2X communication to communicate between the vehicle. In this system we use Automatic Braking System can stop the car to

avoid accident. This system can be implemented in trains and aeroplane. We use ARM7 Microcontroller which enables to use internet. Use of Internet of Things will not be difficult because most of the people use internet in daily life. Use of Internet of Things makes our life smarter and easy.

REFERENCES:

- [1]. Siddharth Mehta “Collision Avoidance System” in SlideShare
- [2]. Sai Ram vakkalagadda “Collision avoidance system, automobile technology, safety system in car.
- [3]. Muhammad Zafran Muhammad Zaly ShahMohd Fo’ad Rohani “Vehicle Collision Avoidance and
Detection System using IOT”
- [4]. Divya K S, K A Drishya, Sakthiprasad, Neenu “Vehicle speed control using CAN”
International Journal
of Science Technology & Engineering |
Volume 1 | Issue 10 | April 2015
- [5]. A.Deepak, M.Sriramprasath, R. Lokesh, M. Sarath Kumar “Automotive Collision Avoidance System”
International Journal of Modern
Engineering Research (IJMER) www.ijmer.com
Pp-106-109 ISSN:
2249-6645. 2011.
- [6]. T.U.Anand Santhosh Kumar1, J. Mrudula2
“Advanced Accident Avoidance System for
Automobiles”
International Journal of Computer
Trends and Technology (IJCTT) –
volume 6 number 2– Dec 2013
- [7]. N.S. Shayan, Vishwas.S. Patel “Collision Avoidance for Vehicle Safety” BMSCE 2011
- [8]. Xue Yang, Jie Liu, Feng Zhao and Nitin H. Vaidya” A Vehicle-to-Vehicle Communication Protocol for
Cooperative Collision Warning” IEEE
2003.

[9]. Mr. Shane Lobo, Mr. Mangesh Gawade,
Mr. Swapnil Karapurkar, Mr. Malcolm Desai
“PC Based

Wireless Mobile Robot Control” Goa
University 2008.

[10] Khairul A’alam bin Abdul Ghani
“OBSTACLE AVOIDANCE MOBILE
ROBOT” University Malaysia Pahang.